

THIS DRAWING IS UNPUBLISHED. RELEASED FOR PUBLICATION 20
 © COPYRIGHT 20 BY TYCO ELECTRONICS CORPORATION. ALL RIGHTS RESERVED.

| LOC | | DIST | | REVISIONS | | | |
|-----|-----|-----------------------|-----------|-----------|------|--|--|
| P | LTR | DESCRIPTION | DATE | DWN | APVD | | |
| | E | REV PER ECR-08-024912 | 19NOV2008 | DDE | SB | | |

- MATERIAL:**
 CONNECTOR HOUSING: POLYESTER PBT, COLOR: SEE TABLE*
 PLUG ASSEMBLY:
 PLUG BODY: PAS, COLOR: BEIGE*
 INTERNAL BODY: BRASS, NICKEL PLATED
 INTERNAL COMPONENTS: PEI, COLOR: NATURAL
 FERRULE: CERAMIC
 FERRULE BASE: ALUMINUM ALLOY
 PLUNGER: ALUMINUM ALLOY
 SPRING: STAINLESS STEEL
 TERMINATION COVER: PEI, COLOR: BLACK*
 PROTECTIVE CAP: VINYL, COLOR: BLACK
 CRIMP EYELET: COPPER, TIN PLATED
 INNER EYELET: BRASS
 POLYMER TUBING: TYGON, COLOR: CLEAR
 HYTREL, COLOR: WHITE
 STRAIN RELIEF/BOOT: POLYOLEFIN ELASTOMER, COLOR: SEE TABLE*
 *UL94 V-0 RATED AT QUALIFYING THICKNESS.

2. THIS KIT WILL TERMINATE:
 900um TIGHT BUFFERED FIBER
 250um COATED FIBER
 2.5-3.0mm JACKETED CABLE
 900um BREAK-OUT KIT
 900um EASY STRIP OR SEMI-TIGHT BUFFERED FIBER
3. TIGHT BUFFER TO BE 900±50um.
4. ANY JACKETED CABLE USED WITH SC CONNECTORS MUST ALLOW FOR THE AXIAL MOVEMENT OF THE BUFFERED FIBER IN THE CABLE JACKET WHICH OCCURS WHEN AN SC CONNECTOR IS MATED TO ANOTHER CONNECTOR OR DEVICE. CERTAIN CABLE CONSTRUCTIONS DO NOT ALLOW AXIAL MOVEMENT AND ARE NOT SUITABLE FOR USE WITH SC CONNECTORS. REFER TO INSPECTION SPECIFICATION 129-1496 FOR A METHOD OF DETERMINING WHETHER A GIVEN CABLE CONSTRUCTION ALLOWS AXIAL MOVEMENT (RESULT OF THE BUFFER PULL TEST SHOULD MEASURE LESS THAN 2 LBF).

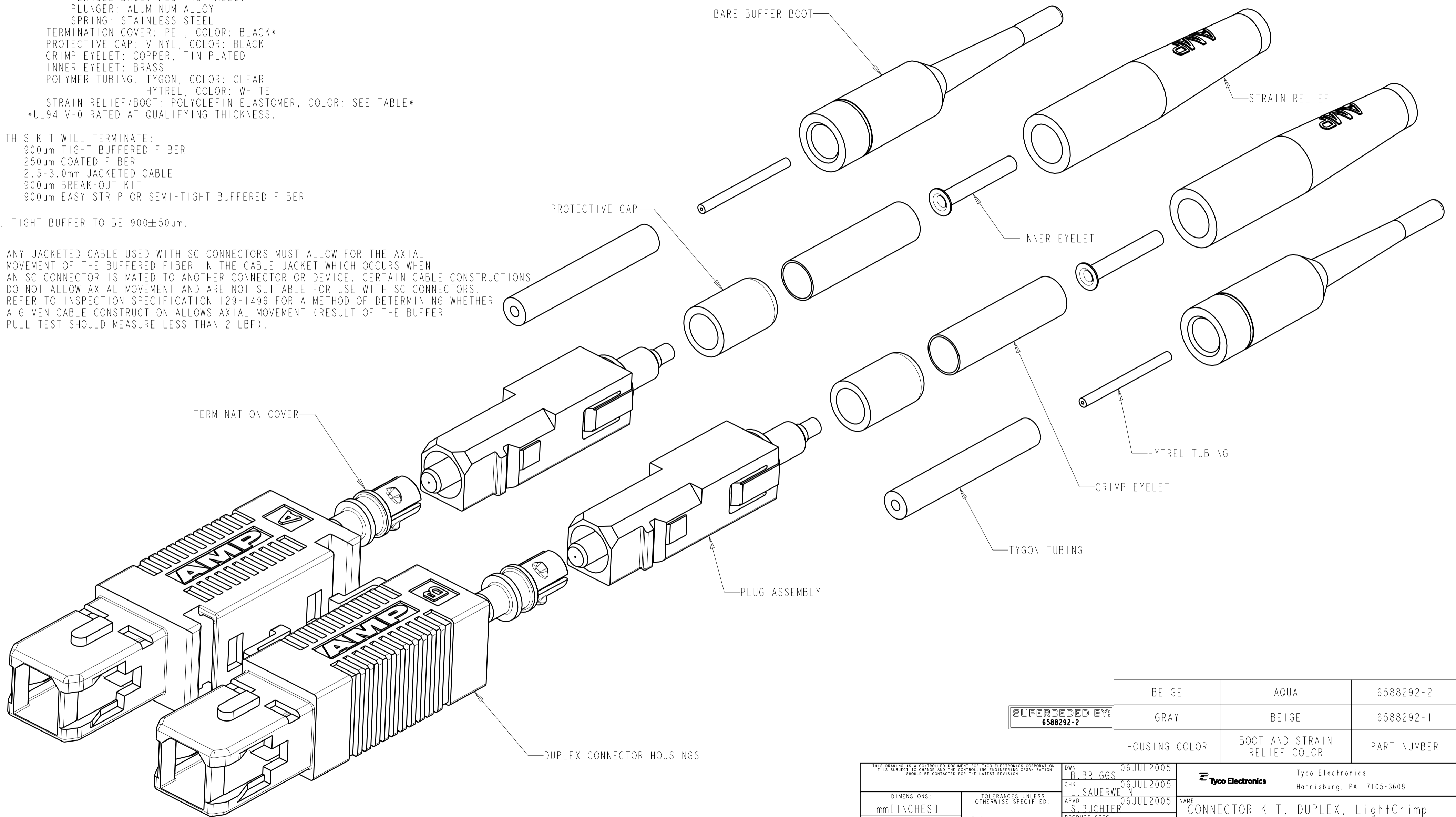

| | | | |
|------------------------------------|---------------|------------------------------|-------------|
| SUPERCEDED BY: 6588292-2 | BEIGE | AQUA | 6588292-2 |
| | GRAY | BEIGE | 6588292-1 |
| | HOUSING COLOR | BOOT AND STRAIN RELIEF COLOR | PART NUMBER |

THIS DRAWING IS A CONTROLLED DOCUMENT FOR TYCO ELECTRONICS CORPORATION. IT IS SUBJECT TO CHANGE AND THE CONTROLLING ENGINEERING ORGANIZATION SHOULD BE CONTACTED FOR THE LATEST REVISION.

| | | | |
|------------------------------|---|--|--|
| DIMENSIONS: mm [INCHES] | TOLERANCES UNLESS OTHERWISE SPECIFIED: 0 PLC ±- 1 PLC ±0.1 2 PLC ±0.02 3 PLC ±0.005 4 PLC ±0.0005 ANGLES ±- FINISH | DWN B. BRIGGS 06 JUL 2005 CHK L. SAUERWEIN APVD S. BUCHTER 06 JUL 2005 | Tyco Electronics Harrisburg, PA 17105-3608 |
| MATERIAL | | PRODUCT SPEC APPLICATION SPEC WEIGHT | NAME CONNECTOR KIT, DUPLEX, LightCrimp Plus SC, XG COMPATIBLE, 50/125um, MM |
| | | SIZE A2 CAGE CODE 00779 DRAWING NO. C-6588292 | RESTRICTED TO |

CUSTOMER DRAWING SCALE 4:1 SHEET 1 OF 1 REV E